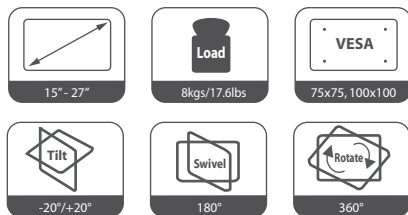









Table Stand VESA Mount Installation Instructions



Installation INSTRUCTIONS

WARNING STATEMENTS

Warning

-  Prior to the installation of this product, the installation instruction must be read and completely understood. Failure to do so may result in personal injury, property damage or voiding of factory warranty.
-  Do not install on a structure that is prone to vibration, movement or chance of impact. Reinforce the structure as required before installation.
-  The desk clamp can support a maximum thickness of 9 cm. Confirm the desk edge before installation.
-  Pay attention to the weight capacity of the mount. Exceeding the limitation can result in function unworkable or even serious personal injury and property damage.
-  Never operate the mount if parts are missing or damaged. Contact your local service center for warranty service.

PRODUCT LINE GRAPH

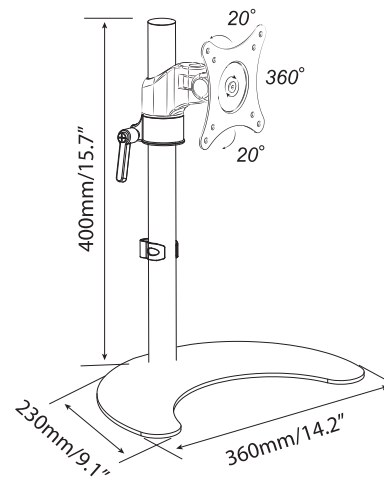





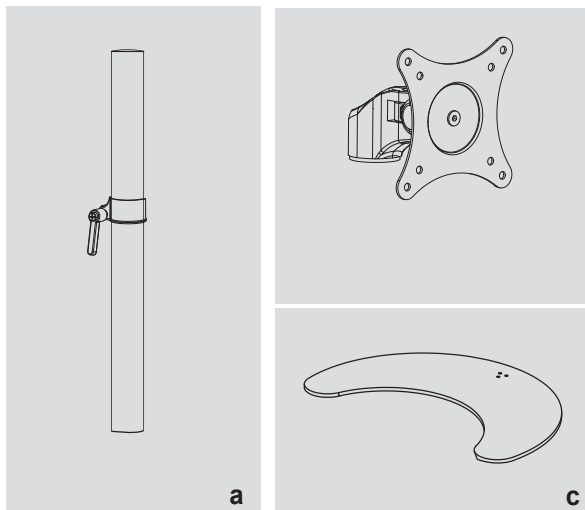

TOOLS REQUIRED NOT INCLUDED



PARTS INCLUDED



A	 M4x12 (x4)	 M4x30 (x4)
	 S=3mm (x1)	 S=4mm (x1)
B	 13X5.5X16.5 (x4)	 (x1)
C	 M6x15(x3)	

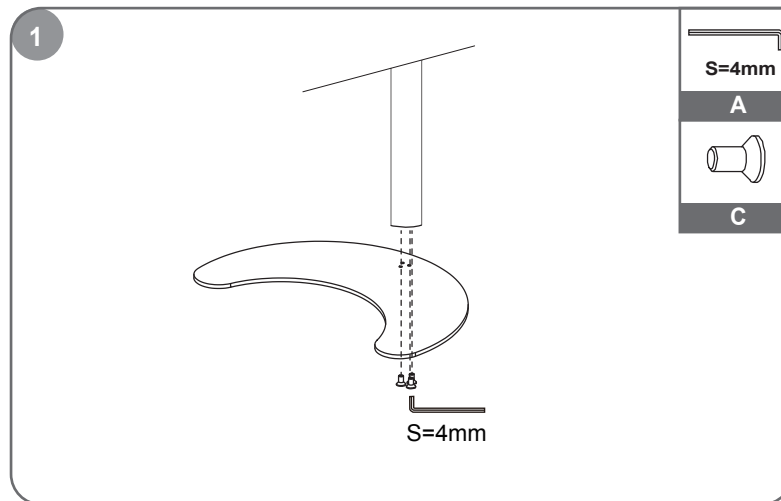

Use screws to connect the base with the steel pipe.

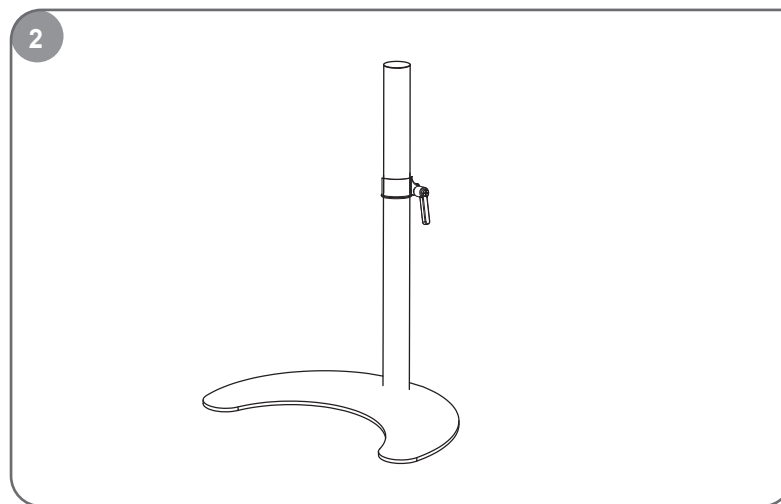

Installation is complete.

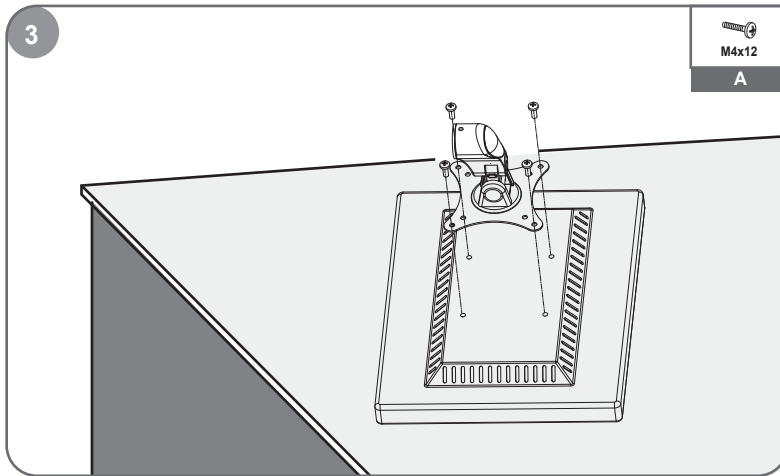

Flush surface installation: Install 4 screws through faceplate to monitor via mounting holes.

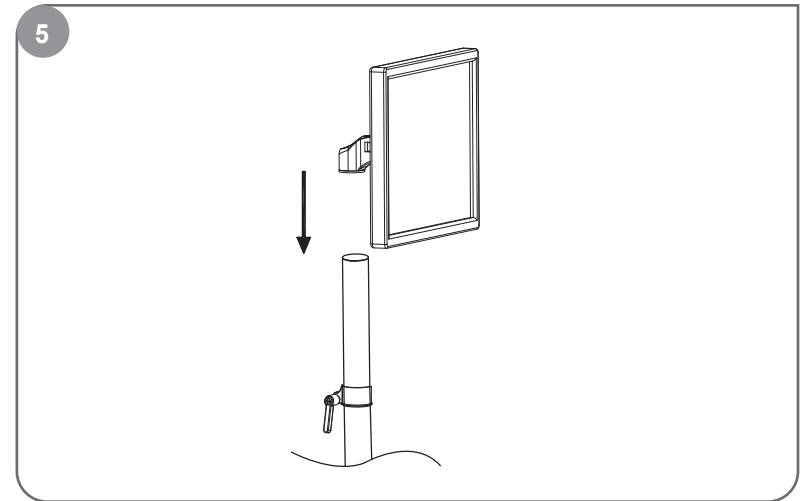

Lift the plate connecting part along with the monitor and put it on the locating ring.

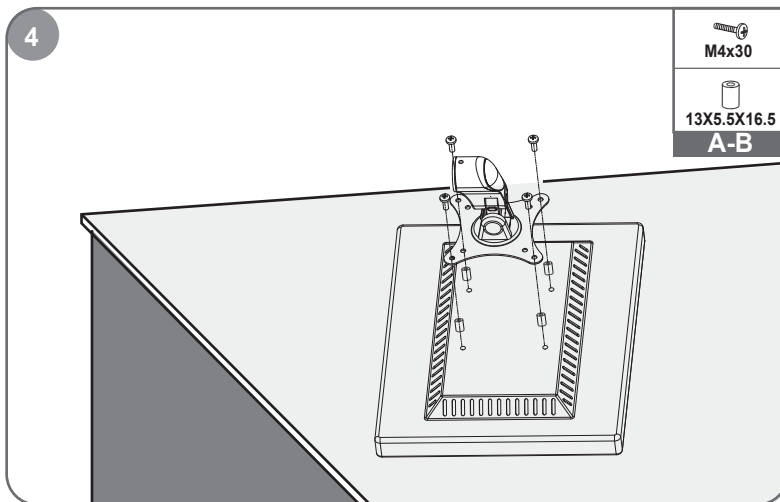

Recessed surface installation: Put 4 spacers between faceplate and monitor. Install 4 screws through faceplate, spacers to monitor via mounting holes.

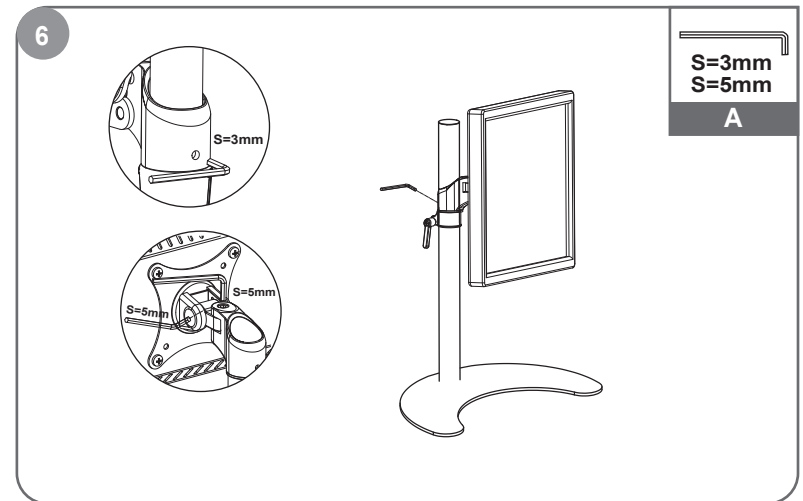

Use a hex wrench to adjust the damp for swiveling. Turn counter-clockwise to reduce damping and clockwise to increase damping.

7



B

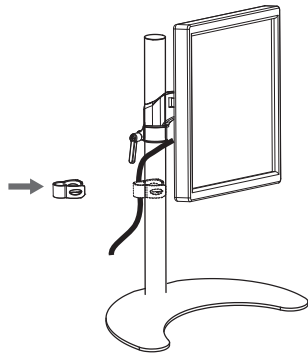

Use cable clamp to limit cables close to steel pipe.