

TD-45-08

8" Industrial Monitor



Key Highlights

- 8" LCD with 800 x 600 Resolution
- Rugged Die Cast Aluminum Chassis
- IP66 Compliant Front Panel
- Optional Optical Bonding
- Resistive or Projected Capacitive Touchscreen
- Full Flat Front Panel

[VIEW ONLINE](#)

The TD-45-08 is a cost effective, versatile [rugged computer monitor solution](#) that fits the needs of many industrial applications. The same model is available in screen sizes from 7" to 21.5". This display includes a wide range 9~36VDC power input for applications that use their own DC voltage source. An optional AC-to-DC power supply is also available for AC powered applications. The TD-45-08 can be panel mounted, making its front bezel IP66 protected against dust and liquids. Or, it can be mounted to an arm, stand, or hung on a surface. This display can be connected to any computer including a rugged box PC or another touchscreen panel PC. The touchscreen monitor provides a graphical user interface where the operator may perform tasks such as: operate a machine, view sensor data, or interact with ERP software.

USA

Teguar
2920 Whitehall Park Drive
Charlotte, NC 28273
+1 866-693-3105
sales@teguar.com

EUROPE

Teguar Europe AG
Churerstrasse 54, CH-8808
Pfäffikon, Switzerland
+41 41 561 53 11
sales.EU@teguar.com

ASIA

Teguar Taiwan Ltd.
Rm. A, 28F-12., No.99, Sec. 1, Xintai 5th Rd.,
Xizhi Dist., New Taipei City 221, Taiwan (R.O.C.)
+886 2 7751 5319
sales@teguar.com.tw

Technical Specifications

Display

Screen Size	8"
Screen Ratio	4:03
Brightness	350 nits, Optional 1000 nit High Brightness

Power

Input Voltage Range	9-32V DC
Max Power Consumption	4.7W (Resistive), 3.6W (P-Cap)
Standard Power Adapter	Optional 12V AC/DC Adapter

Enclosure

Material	Aluminum
IP Rating	IP66 Front Bezel
Color	Silver
Mounting Options	Panel Mount, VESA Mount
Approved Cleaning Solutions	Acetone, Alcohol, Club Soda, Hydrochloric Acid, Methyl Alcohol, Mineral Spirits, Nitric Acid, Sulfuric Acid (low concentration), Vinegar, Warm Water

Warranty

Warranty	Up to 5 Years
----------	---------------

Specifications subject to change.

Touch Screen

Touch Screen	Projected Capacitive, Resistive
--------------	---------------------------------

External I/O Ports

Audio Ports	1x 3.5mm Audio Line-Out
Power Input Port	3-Pin DC-In (Phoenix Type)

Thermal & Environmental

Operating Temperature	0°C - 50°C (32°F - 122°F), -20°C - 60°C (Optional -4°F - 140°F)
Storage Temperature	-30°C - 70°C (-22°F - 158°F)
Cooling Solution	Passive - Fanless
Storage Humidity	10% - 90% Non-condensing

Weight / Dimensions

Weight	1.8 kg (4.0 lbs)
Dimensions	231.1 x 176.1 x 50 mm (9.1 x 6.9 x 2.0 in)

Certification

Certifications	CE, FCC Class A
----------------	-----------------

USA

Teguar
2920 Whitehall Park Drive
Charlotte, NC 28273
+1 866-693-3105
sales@teguar.com

EUROPE

Teguar Europe AG
Churerstrasse 54, CH-8808
Pfäffikon, Switzerland
+41 41 561 53 11
sales.EU@teguar.com

ASIA

Teguar Taiwan Ltd.
Rm. A, 28F-12., No.99, Sec. 1, Xintai 5th Rd.,
Xizhi Dist., New Taipei City 221, Taiwan (R.O.C.)
+886 2 7751 5319
sales@teguar.com.tw

I/O Diagram Images

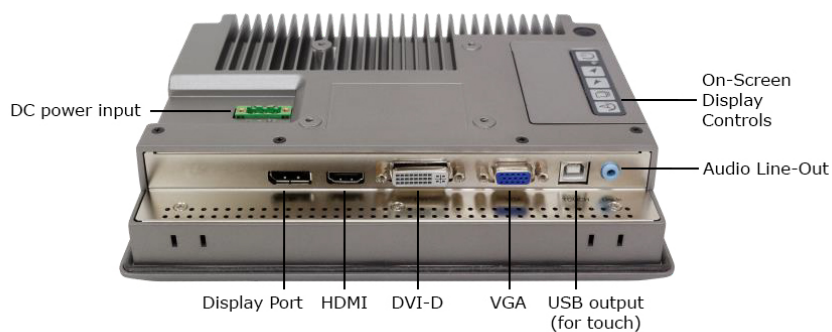

Tech Diagram Images

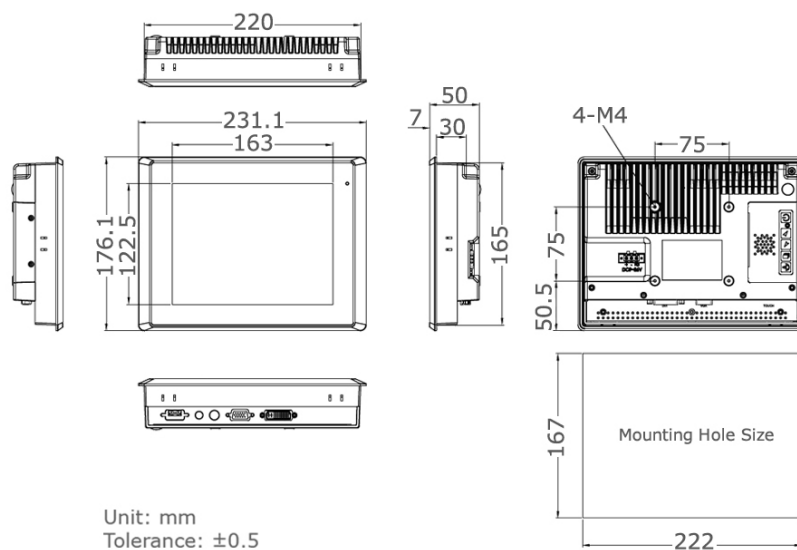

USA

Teguar
2920 Whitehall Park Drive
Charlotte, NC 28273
+1 866-693-3105
sales@teguar.com

EUROPE

Teguar Europe AG
Churerstrasse 54, CH-8808
Pfäffikon, Switzerland
+41 41 561 53 11
sales.EU@teguar.com

ASIA

Teguar Taiwan Ltd.
Rm. A, 28F-12., No.99, Sec. 1, Xintai 5th Rd.,
Xizhi Dist., New Taipei City 221, Taiwan (R.O.C.)
+886 2 7751 5319
sales@teguar.com.tw