

TMD-25-15

15.6" Medical Grade Display



Key Highlights

- 15.6" Projected Capacitive Touchscreen
- IEC 60601-1 Medically Certified
- VGA and HDMI Inputs
- High Resolution 1920 x 1080 Display
- Slim and Light Weight Design

[VIEW ONLINE](#)

The TMD-25-15 is a medically certified touchscreen display with a projected-capacitive multi-touch screen. The 1920 x 1080 resolution display provides high quality image reproduction for viewing patient images or electronic medical records. This healthcare monitor has both VGA and HDMI inputs for video, USB for touch, and audio for the built in speakers. This display has various VESA mounting hole patterns, for mounting on a desktop stand, ergonomic arm, medical cart, or medical machine. The TMD-25-15 is a stylish and elegant display that will deliver reliable performance in your healthcare setting.

USA

Teguar
2920 Whitehall Park Drive
Charlotte, NC 28273
+1 866-693-3105
sales@teguar.com

EUROPE

Teguar Europe AG
Churerstrasse 54, CH-8808
Pfäffikon, Switzerland
+41 41 561 53 11
sales.EU@teguar.com

ASIA

Teguar Taiwan Ltd.
Rm. A, 28F-12., No.99, Sec. 1, Xintai 5th Rd.,
Xizhi Dist., New Taipei City 221, Taiwan (R.O.C.)
+886 2 7751 5319
sales@teguar.com.tw

Technical Specifications

Display

Screen Size	15.6"
Resolution	1920 x 1080 (Full HD)
Brightness	300 nits

Power

Standard Power Adapter	External AC to DC Adapter (complies with Level VI efficiency standard)
------------------------	--

Weight / Dimensions

Weight	1.6 kg (3.5 lbs)
Dimensions	387.8 x 232.9 x 38.4 mm (15.3 x 9.2 x 1.5 in)

Certification

Certifications	60601-1 4th Edition
----------------	---------------------

Specifications subject to change.

Touch Screen

Touch Screen	Projected Capacitive (Multi-touch)
--------------	------------------------------------

External I/O Ports

USB	1x USB 2.0
Audio Ports	1x 3.5mm Audio Line-In

Enclosure

Color	White
Control Buttons	Down, Input, Left, Menu, Right, Up
Mounting Options	VESA 75 Mount

Warranty

Warranty	Up to 5 Years
----------	---------------

USA

Teguar
2920 Whitehall Park Drive
Charlotte, NC 28273
+1 866-693-3105
sales@teguar.com

EUROPE

Teguar Europe AG
Churerstrasse 54, CH-8808
Pfäffikon, Switzerland
+41 41 561 53 11
sales.EU@teguar.com

ASIA

Teguar Taiwan Ltd.
Rm. A, 28F-12., No.99, Sec. 1, Xintai 5th Rd.,
Xizhi Dist., New Taipei City 221, Taiwan (R.O.C.)
+886 2 7751 5319
sales@teguar.com.tw

I/O Diagram Images

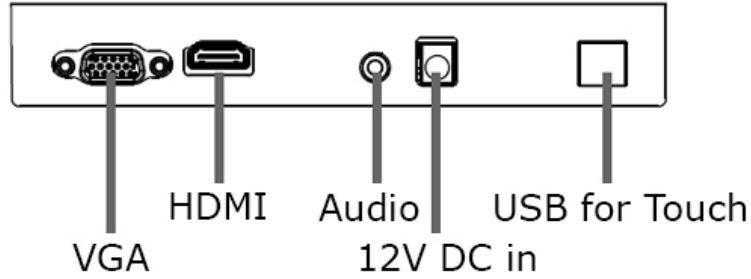
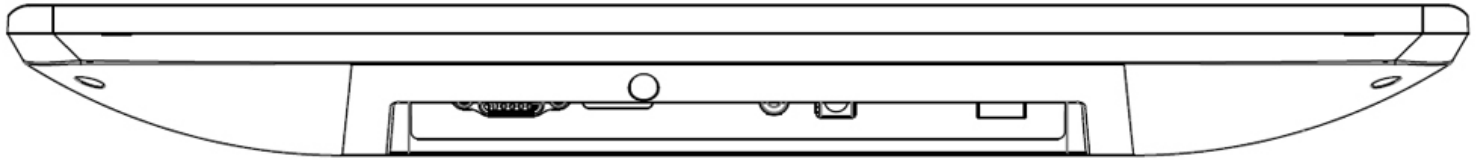

USA

Teguar
2920 Whitehall Park Drive
Charlotte, NC 28273
+1 866-693-3105
sales@teguar.com

EUROPE

Teguar Europe AG
Churerstrasse 54, CH-8808
Pfäffikon, Switzerland
+41 41 561 53 11
sales.EU@teguar.com

ASIA

Teguar Taiwan Ltd.
Rm. A, 28F-12., No.99, Sec. 1, Xintai 5th Rd.,
Xizhi Dist., New Taipei City 221, Taiwan (R.O.C.)
+886 2 7751 5319
sales@teguar.com.tw

Tech Diagram Images

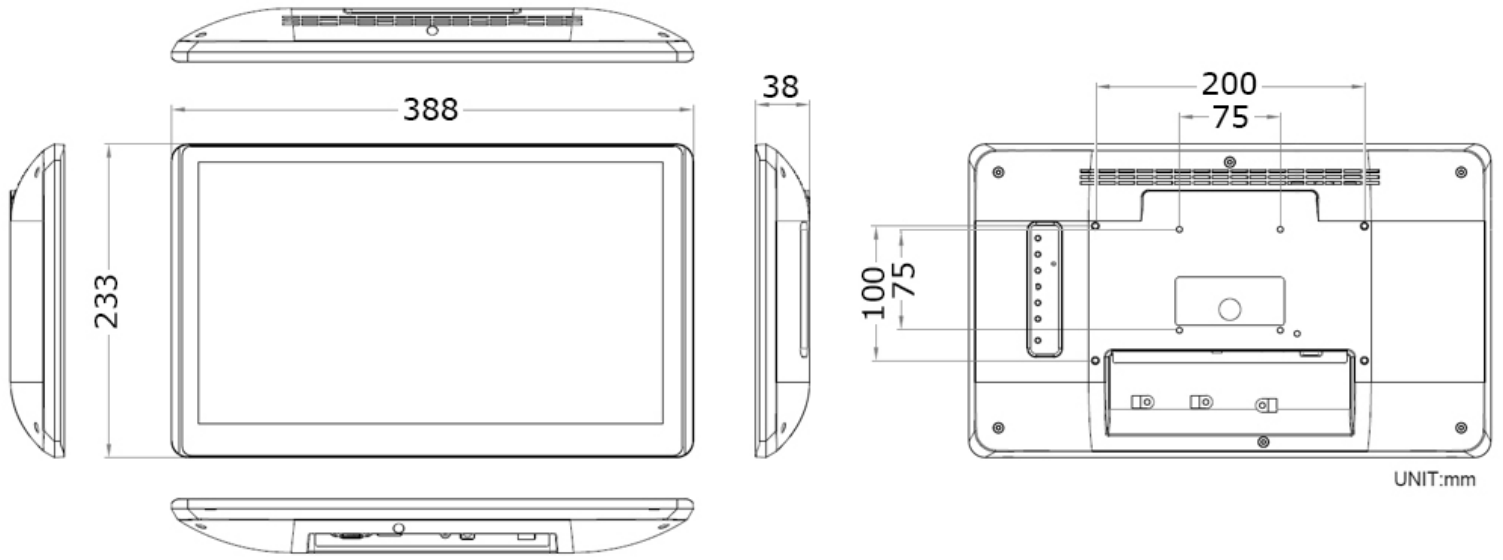

USA

Teguar
2920 Whitehall Park Drive
Charlotte, NC 28273
+1 866-693-3105
sales@teguar.com

EUROPE

Teguar Europe AG
Churerstrasse 54, CH-8808
Pfäffikon, Switzerland
+41 41 561 53 11
sales.EU@teguar.com

ASIA

Teguar Taiwan Ltd.
Rm. A, 28F-12., No.99, Sec. 1, Xintai 5th Rd.,
Xizhi Dist., New Taipei City 221, Taiwan (R.O.C.)
+886 2 7751 5319
sales@teguar.com.tw