

TSC-5010-22

22" IP69K PC



Key Highlights

- 21.5" Widescreen LCD
- Intel Core i5 Dual-Core CPU
- Sealed I/O Design for Standard Cables
- Resistive or P-Cap Touch
- IP66 & IP69K (Optional IP67) Rated Enclosure

[VIEW ONLINE](#)

The TSC-5010-22 has a unique cable feedthrough design that allows you to use standard cables with the I/O ports, while maintaining a full IP67/IP69K waterproof rating. This means you don't need custom M12 cables and all I/O connections are sealed. The 21.5" widescreen HD display is available with P-Cap or Resistive touch, and high brightness and optical bonding. This PC has rustproof, fully sealed stainless steel housing for use in wash-down environments, such as in a food and beverage processing plant or on a pharmaceutical manufacturing line. The TSC-5010-22 can be VESA or yoke mounted onto a desktop stand, wall mount, machine, mobile cart, ergonomic arm, and more.

This product is now considered "Previous Generation" meaning it may or may not still be available for purchase. Call +1 800 870 7715 for details on this product or check out our full list of currently available [Waterproof Computers](#).

USA

Teguar
2920 Whitehall Park Drive
Charlotte, NC 28273
+1 866-693-3105
sales@teguar.com

EUROPE

Teguar Europe AG
Churerstrasse 54, CH-8808
Pfäffikon, Switzerland
+41 41 561 53 11
sales.EU@teguar.com

ASIA

Teguar Taiwan Ltd.
Rm. A, 28F-12, No.99, Sec. 1, Xintai 5th Rd.,
Xizhi Dist., New Taipei City 221, Taiwan (R.O.C.)
+886 2 7751 5319
sales@teguar.com.tw

Technical Specifications

Primary Components

Processor Family	Intel Core I series 6th Generation Skylake
Processor Model	Core i5-6200U
Processor Speed	2.3 GHz
Memory Type	2x DDR4 SO-DIMM
Memory Support	4GB, 8GB, 16GB, 32GB
Storage Type	1x 2.5" SATA Drive Bay for SSD/HDD
Storage Support	32GB-1TB

External I/O Ports

USB	4x USB 3.0
Serial / Com	2x COM
Serial Protocol Detail	1x RS-232, 1x RS-232/422/485 (Jumperless configuration in BIOS)
Ethernet / LAN	2x RJ45 GbE LAN
Video Outputs	2x DisplayPort
Audio Ports	1x Audio Line-Out
Power Input Port	M12 type 5-PIN DC-in

Expansion Slots

Internal M.2	1x M.2 Type E
--------------	---------------

Thermal & Environmental

Operating Temperature	0°C - 40°C (32°F - 104°F)
Storage Temperature	-20°C - 60°C (-4°F - 140°F)
Cooling Solution	Passive - Fanless
Humidity Range	10% - 90% Non-condensing
Storage Humidity	10% - 90% Non-condensing

Peripherals & Wireless Connectivity

WiFi	Optional WiFi + Bluetooth Flat Antenna Kit
Barcode Scanner	Optional 1D/2D Barcode Scanner

Certification

Certifications	CE, FCC, VCCI Class B
----------------	-----------------------

Display

Screen Size	21.5
Resolution	1920 x 1080 (Full HD)
Screen Ratio	16:9
Brightness	250 nits, Optional 1000 nit High Brightness

Touch Screen

Touch Screen	Projected Capacitive, Resistive
Hardness	4H

Power

Input Voltage Range	9-32V DC
Max Power Consumption	58.9W
Standard Power Adapter	AC 100 - 240V / 47 ~ 63 Hz / DC Output 12V, IP68, AC Cable 2130MM

Operating Systems

Windows	Windows 10 IoT, Windows 10 Pro, Windows 7 Pro
---------	---

Compatibility

Security Hardware	Optional TPM 2.0
-------------------	------------------

Multimedia

Speakers	Optional Speaker
----------	------------------

Enclosure

Material	Optional SUS316 Stainless Steel, SUS304 Stainless Steel
IP Rating	IP66, IP69K, Optional IP67
Color	Stainless Steel
Control Buttons	Power Button
Mounting Options	Table Mount, VESA 100 Mount, Wall Mount

Approved Cleaning Solutions	Acetic Acid (low concentration), Ammonium Nitrate (low concentration), Benzene, Citric Acid (low concentration), Ethanol, Ethylene Glycol Solution (1:1 with water), Hexane, Hydrochloric Acid (low concentration), Iron Chloride Solution, Isooctane, Isopropyl Alcohol, Nitric Acid (low concentration), Paraffin, Perhydrol (30% in water), Phosphoric Acid (low concentration), Propane, Silicone Oil, Sodium Carbonate (low concentration), Sodium Chloride Solution, Sodium Nitrate (low concentration), Sulfuric Acid (low concentration), Triethylene Glycol
-----------------------------	--

Weight / Dimensions

Weight	17.1 kg (37.7 lbs)
Dimensions	557 x 358.5 x 105 mm (21.9 x 14.1 x 4.1 in)

Warranty

Warranty	Up to 5 Years
----------	---------------

USA

Teguar
2920 Whitehall Park Drive
Charlotte, NC 28273
+1 866-693-3105
sales@teguar.com

EUROPE

Teguar Europe AG
Churerstrasse 54, CH-8808
Pfäffikon, Switzerland
+41 41 561 53 11
sales.EU@teguar.com

ASIA

Teguar Taiwan Ltd.
Rm. A, 28F-12., No.99, Sec. 1, Xintai 5th Rd.,
Xizhi Dist., New Taipei City 221, Taiwan (R.O.C.)
+886 2 7751 5319
sales@teguar.com.tw

I/O Diagram Images



USA

Teguar
2920 Whitehall Park Drive
Charlotte, NC 28273
+1 866-693-3105
sales@teguar.com

EUROPE

Teguar Europe AG
Churerstrasse 54, CH-8808
Pfäffikon, Switzerland
+41 41 561 53 11
sales.EU@teguar.com

ASIA

Teguar Taiwan Ltd.
Rm. A, 28F-12., No.99, Sec. 1, Xintai 5th Rd.,
Xizhi Dist., New Taipei City 221, Taiwan (R.O.C.)
+886 2 7751 5319
sales@teguar.com.tw

Tech Diagram Images

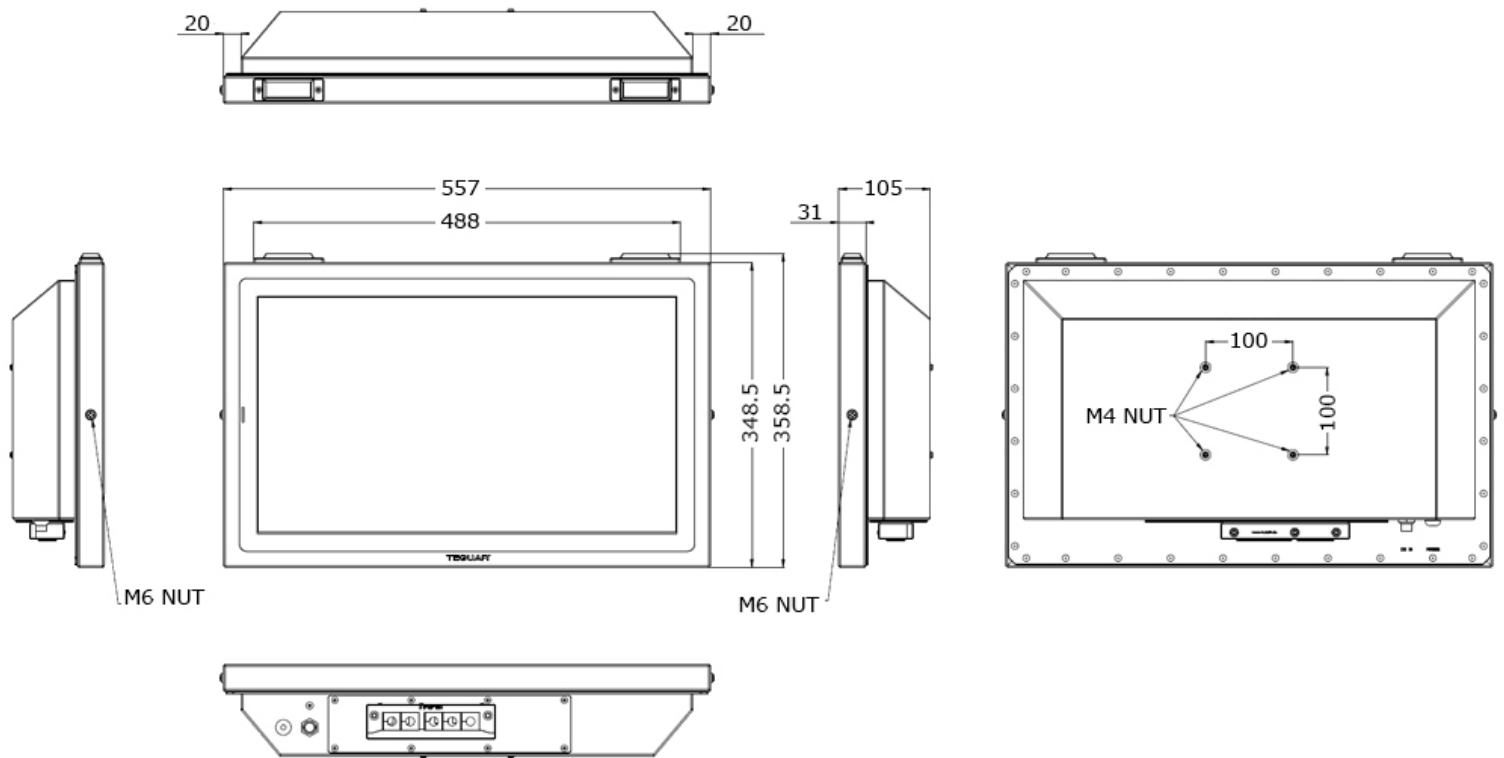

USA

Teguar
2920 Whitehall Park Drive
Charlotte, NC 28273
+1 866-693-3105
sales@teguar.com

EUROPE

Teguar Europe AG
Churerstrasse 54, CH-8808
Pfäffikon, Switzerland
+41 41 561 53 11
sales.EU@teguar.com

ASIA

Teguar Taiwan Ltd.
Rm. A, 28F-12., No.99, Sec. 1, Xintai 5th Rd.,
Xizhi Dist., New Taipei City 221, Taiwan (R.O.C.)
+886 2 7751 5319
sales@teguar.com.tw