

TD-45-16

15.6" Industrial Display



Key Highlights

- 15.6" High Resolution LCD Touchscreen
- Rugged Die Cast Aluminum Enclosure
- Optional Sunlight Readable 1000 Nit LCD
- IP66 Compliant Front Panel
- Resistive or Projected Capacitive Touchscreen
- Wide Range DC 9~36V Power Input

[VIEW ONLINE](#)

The TD-45-16 is a versatile display that can be mounted into a cutout in an enclosure or it can be mounted to an arm, stand, or hung from a surface. When panel mounted, the front bezel is IP66 rated for protection from liquids and dust. The same model is available in screen sizes from 7" to 21.5" and can be connected to any computer. The TD-45-16 is often connected to a fanless box PC, offering a rugged, long-life solution. This display can also be connected to another touchscreen panel PC, where it can operate as a cloned display or an extended desktop. This touchscreen display includes a wide range 9~36VDC power input for applications that use their own DC voltage source. An optional AC-to-DC power supply is also available for AC powered applications. The TD-45-16 is ideal for mounting into control cabinets, integrating onto an OEM machine, or operating in a manufacturing environment.

USA

Teguar
2920 Whitehall Park Drive
Charlotte, NC 28273
+1 866-693-3105
sales@teguar.com

EUROPE

Teguar Europe AG
Churerstrasse 54, CH-8808
Pfäffikon, Switzerland
+41 41 561 53 11
sales.EU@teguar.com

ASIA

Teguar Taiwan Ltd.
Rm. A, 28F-12., No.99, Sec. 1, Xintai 5th Rd.,
Xizhi Dist., New Taipei City 221, Taiwan (R.O.C.)
+886 2 7751 5319
sales@teguar.com.tw

Technical Specifications

Display	
Screen Size	15.6"
Screen Resolution	1366 x 768, Optional 1920 x 1080
Screen Ratio	16:09
Brightness	300 nits, Optional 1000 nit High Brightness

Power	
Input Voltage Range	9-32V DC
Max Power Consumption	12.2W (Resistive), 12.3W (P-Cap)
Standard Power Adapter	Optional 12V AC/DC Adapter

Enclosure	
Material	Aluminum
IP Rating	IP66 Front Bezel
Color	Silver
Mounting Options	Panel Mount, VESA 100 Mount
Approved Cleaning Solutions	Alcohol, Chlorine and Compounds, Glutaraldehyde, Hydrogen Peroxide, Ortho-phthalaldehyde (OPA), Quaternary Ammonium Compounds

Certification	
Certifications	CE, FCC Class A

Specifications subject to change.

Touch Screen	
Touch Screen	Projected Capacitive, Resistive

External I/O Ports	
Audio Ports	1x Optional Speaker with 1x Audio Input
Power Input Port	3-Pin DC-In (Phoenix Type)

Multimedia	
Speakers	Optional Speaker

Thermal & Environmental	
Operating Temperature	-20°C - 60°C (-4°F - 140°F)
Storage Temperature	-30°C - 70°C (-22°F - 158°F)
Cooling Solution	Passive - Fanless
Storage Humidity	10% - 90% Non-condensing

Weight / Dimensions	
Weight	4.4 kg (9.7 lbs)
Dimensions	412 x 277.5 x 58.9 mm (16.2 x 10.9 x 2.3 in)

Warranty	
Warranty	Up to 5 Years

USA

Teguar
2920 Whitehall Park Drive
Charlotte, NC 28273
+1 866-693-3105
sales@teguar.com

EUROPE

Teguar Europe AG
Churerstrasse 54, CH-8808
Pfäffikon, Switzerland
+41 41 561 53 11
sales.EU@teguar.com

ASIA

Teguar Taiwan Ltd.
Rm. A, 28F-12., No.99, Sec. 1, Xintai 5th Rd.,
Xizhi Dist., New Taipei City 221, Taiwan (R.O.C.)
+886 2 7751 5319
sales@teguar.com.tw

I/O Diagram Images

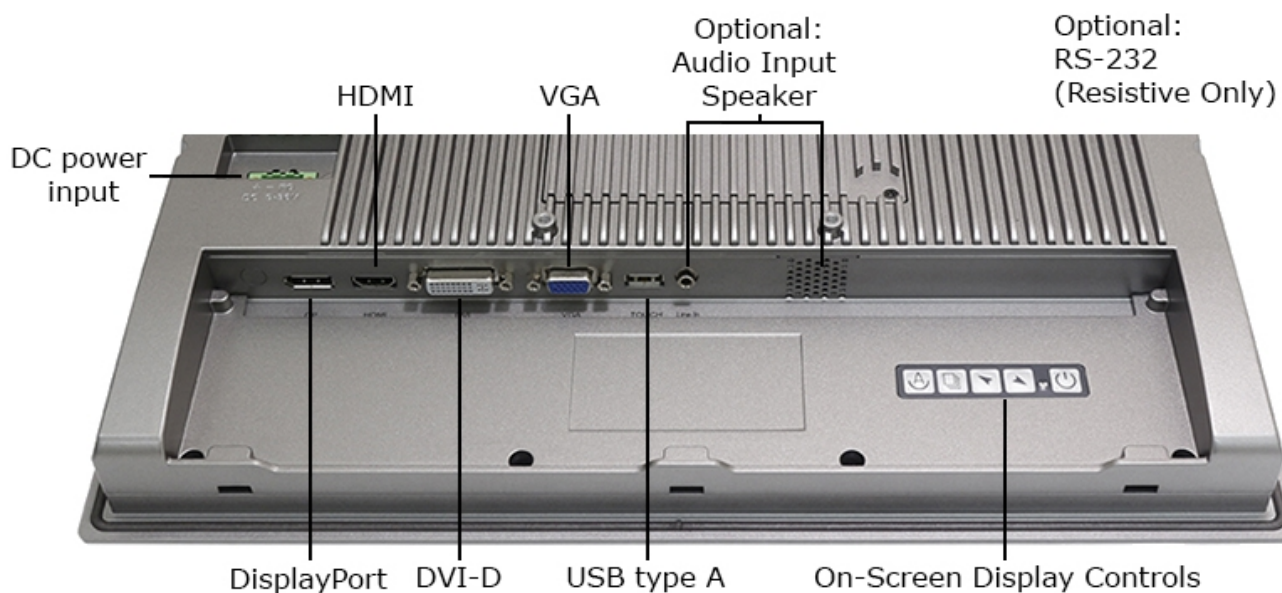

USA

Teguar
2920 Whitehall Park Drive
Charlotte, NC 28273
+1 866-693-3105
sales@teguar.com

EUROPE

Teguar Europe AG
Churerstrasse 54, CH-8808
Pfäffikon, Switzerland
+41 41 561 53 11
sales.EU@teguar.com

ASIA

Teguar Taiwan Ltd.
Rm. A, 28F-12., No.99, Sec. 1, Xintai 5th Rd.,
Xizhi Dist., New Taipei City 221, Taiwan (R.O.C.)
+886 2 7751 5319
sales@teguar.com.tw

Tech Diagram Images

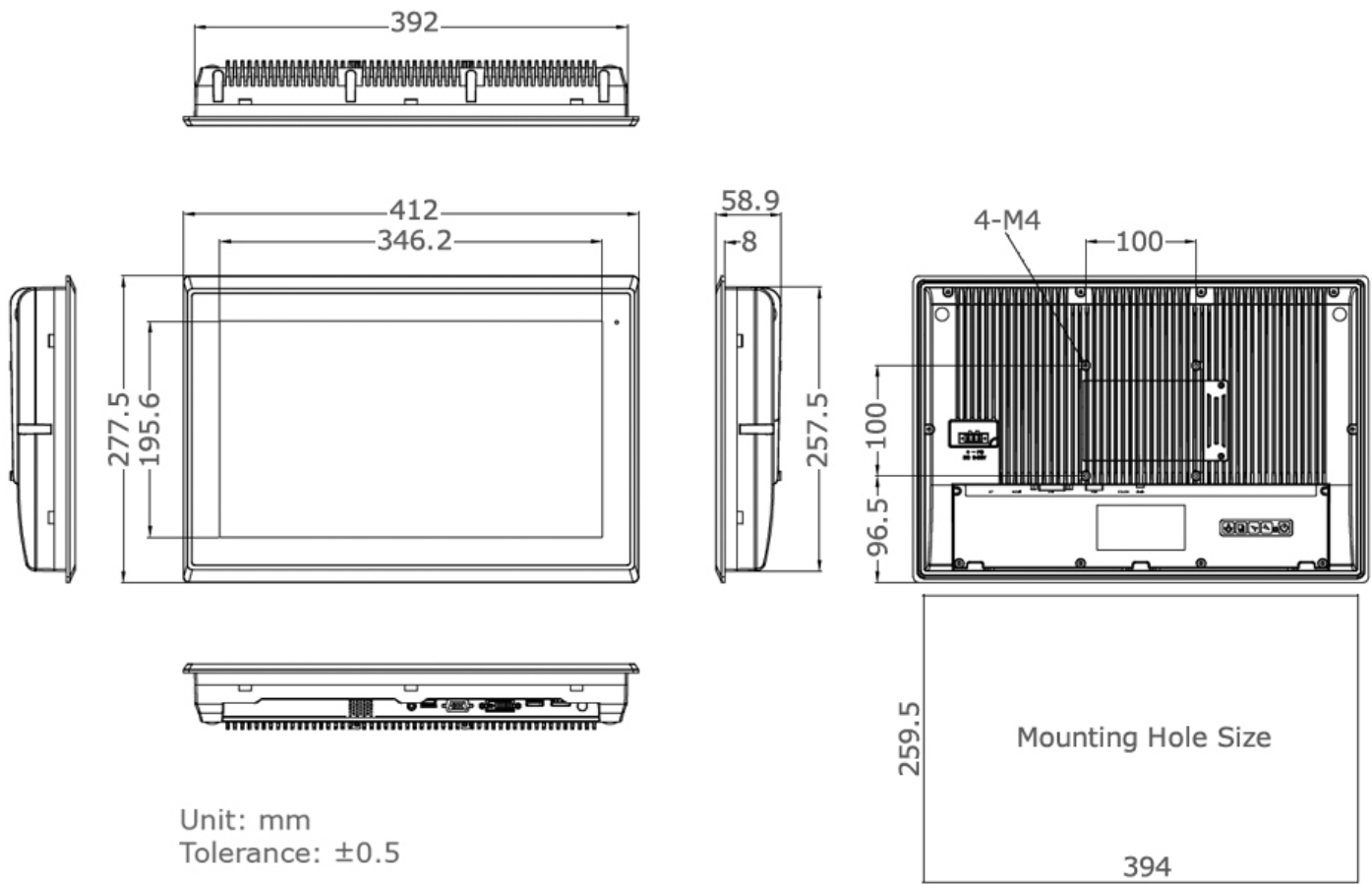

USA

Teguar
2920 Whitehall Park Drive
Charlotte, NC 28273
+1 866-693-3105
sales@teguar.com

EUROPE

Teguar Europe AG
Churerstrasse 54, CH-8808
Pfäffikon, Switzerland
+41 41 561 53 11
sales.EU@teguar.com

ASIA

Teguar Taiwan Ltd.
Rm. A, 28F-12., No.99, Sec. 1, Xintai 5th Rd.,
Xizhi Dist., New Taipei City 221, Taiwan (R.O.C.)
+886 2 7751 5319
sales@teguar.com.tw