

# TSC-4010-15

## 15" Waterproof Cable Gland Computer



### Key Highlights

- 15" LCD Touchscreen
- Intel Celeron J1900 CPU
- Sealed Cable Gland Design
- IP66, IP69K, Optional IP67
- Full Waterproof Stainless Steel Housing

[VIEW ONLINE](#)

The TSC-4010-15 is IP66/IP69K waterproof rated, for use in wash down environments, such as food and beverage manufacturing facilities and pharmaceutical processing plants. The sealed I/O cover allows you to use standard cables, while maintaining a fully waterproof system. This computer runs on an efficient Intel Celeron CPU and has optional TPM 2.0 hardware security. The TSC-4010-15 has a 15" LED touchscreen, available with P-Cap or resistive touch, and high brightness and optical bonding. This computer also has the option to upgrade to grade SUS316L stainless steel, for use in salt water environments.

**This product is now considered "Previous Generation" meaning it may or may not still be available for purchase. Call +1 800 870 7715 for details on this product or check out our full list of currently available [Waterproof Computers](#).**

#### USA

Teguar  
2920 Whitehall Park Drive  
Charlotte, NC 28273  
+1 866-693-3105  
[sales@teguar.com](mailto:sales@teguar.com)

#### EUROPE

Teguar Europe AG  
Churerstrasse 54, CH-8808  
Pfäffikon, Switzerland  
+41 41 561 53 11  
[sales.EU@teguar.com](mailto:sales.EU@teguar.com)

#### ASIA

Teguar Taiwan Ltd.  
Rm. A, 28F-12., No.99, Sec. 1, Xintai 5th Rd.,  
Xizhi Dist., New Taipei City 221, Taiwan (R.O.C.)  
+886 2 7751 5319  
[sales@teguar.com.tw](mailto:sales@teguar.com.tw)

# Technical Specifications

## Primary Components

|                  |                                    |
|------------------|------------------------------------|
| Processor Family | Intel Celeron Bay Trail            |
| Processor Model  | J1900 Quad Core                    |
| Processor Speed  | 2.0 GHz                            |
| Memory Type      | 2x DDR3 SO-DIMM                    |
| Memory Support   | 2GB, 4GB, 8GB                      |
| Storage Type     | 1x 2.5" SATA Drive Bay for SSD/HDD |
| Storage Support  | 32GB-1TB                           |

## External I/O Ports

|                        |   |
|------------------------|---|
| USB                    | 1x USB 3.0, 3x USB 2.0  |
| Serial / Com           | 2x COM  |
| Serial Protocol Detail | 1x RS-232, 1x RS-232/422/485 (RS485 supports auto flow control, Jumperless configuration in BIOS) |
| Ethernet / LAN         | 2x RJ45 GbE LAN   |
| Video Outputs          | 1x DVI-I  |
| Audio Ports            | 1x Audio Line-Out   |
| Power Input Port       | M12 type 5-PIN DC-in  |

## Expansion Slots

|              |               |
|--------------|---------------|
| Internal M.2 | 1x M.2 Type E |
|--------------|---------------|

## Thermal & Environmental

|                       |                             |
|-----------------------|-----------------------------|
| Operating Temperature | 0°C - 40°C (32°F - 104°F)   |
| Storage Temperature   | -20°C - 60°C (-4°F - 140°F) |
| Cooling Solution      | Passive - Fanless           |
| Humidity Range        | 10% - 90% Non-condensing    |
| Storage Humidity      | 10% - 90% Non-condensing    |

## Peripherals & Wireless Connectivity

|                 |  |
|-----------------|--|
| WiFi            | Optional WiFi + Bluetooth Flat Antenna Kit |
| Barcode Scanner | Optional 1D/2D Barcode Scanner             |

## Certification

|                |                       |
|----------------|-----------------------|
| Certifications | CE, FCC, VCCI Class B |
|----------------|-----------------------|

## Display

|                   |                                   |
|-------------------|-----------------------------------|
| Screen Size       | 15"                               |
| Screen Resolution | 1024 x 768 (XGA)                  |
| Screen Ratio      | 4:3                               |
| Brightness        | Optional 1000 nit High Brightness |

## Touch Screen

|              |                                 |
|--------------|---------------------------------|
| Touch Screen | Projected Capacitive, Resistive |
| Hardness     | 4H                              |

## Power

|                        |  |
|------------------------|--|
| Input Voltage Range    | 7-32V DC   |
| Max Power Consumption  | 30.1W  |
| Standard Power Adapter | AC 90 ~ 264V / 47 ~ 63 Hz / DC Output 12V, IP68, AC Cable 2130MM |

## Operating Systems

|         |   |
|---------|---|
| Windows | Windows 10 IoT, Windows 10 Pro, Windows 7 Pro |
|---------|---|

## Compatibility

|                   |                  |
|-------------------|------------------|
| Security Hardware | Optional TPM 2.0 |
|-------------------|------------------|

## Multimedia

|          |                  |
|----------|------------------|
| Speakers | Optional Speaker |
|----------|------------------|

## Enclosure

|                  |   |
|------------------|---|
| Material         | Optional SUS316 Stainless Steel, SUS304 Stainless Steel |
| IP Rating        | IP66, IP69K, Optional IP67                              |
| Color            | Stainless Steel   |
| Control Buttons  | Power Button  |
| Mounting Options | Table Mount, VESA 100 Mount, Wall Mount                 |

|                             |  |
|-----------------------------|--|
| Approved Cleaning Solutions | Acetic Acid (low concentration), Ammonium Nitrate (low concentration), Benzene, Citric Acid (low concentration), Ethanol, Ethylene Glycol Solution (1:1 with water), Hexane, Hydrochloric Acid (low concentration), Iron Chloride Solution, Isooctane, Isopropyl Alcohol, Nitric Acid (low concentration), Paraffin, Perhydrol (30% in water), Phosphoric Acid (low concentration), Propane, Silicone Oil, Sodium Carbonate (low concentration), Sodium Chloride Solution, Sodium Nitrate (low concentration), Sulfuric Acid (low concentration), Triethylene Glycol |
|-----------------------------|--|

## Weight / Dimensions

|            |   |
|------------|---|
| Weight     | 7.6 kg (16.8 lbs)                           |
| Dimensions | 395 x 319.5 x 105 mm (15.6 x 12.6 x 4.1 in) |

## Warranty

|          |               |
|----------|---------------|
| Warranty | Up to 5 Years |
|----------|---------------|

### USA

Teguar  
2920 Whitehall Park Drive  
Charlotte, NC 28273  
+1 866-693-3105  
sales@teguar.com

### EUROPE

Teguar Europe AG  
Churerstrasse 54, CH-8808  
Pfäffikon, Switzerland  
+41 41 561 53 11  
sales.EU@teguar.com

### ASIA

Teguar Taiwan Ltd.  
Rm. A, 28F-12., No.99, Sec. 1, Xintai 5th Rd.,  
Xizhi Dist., New Taipei City 221, Taiwan (R.O.C.)  
+886 2 7751 5319  
sales@teguar.com.tw

## I/O Diagram Images



### USA

Teguar  
2920 Whitehall Park Drive  
Charlotte, NC 28273  
+1 866-693-3105  
sales@teguar.com

### EUROPE

Teguar Europe AG  
Churerstrasse 54, CH-8808  
Pfäffikon, Switzerland  
+41 41 561 53 11  
sales.EU@teguar.com

### ASIA

Teguar Taiwan Ltd.  
Rm. A, 28F-12., No.99, Sec. 1, Xintai 5th Rd.,  
Xizhi Dist., New Taipei City 221, Taiwan (R.O.C.)  
+886 2 7751 5319  
sales@teguar.com.tw

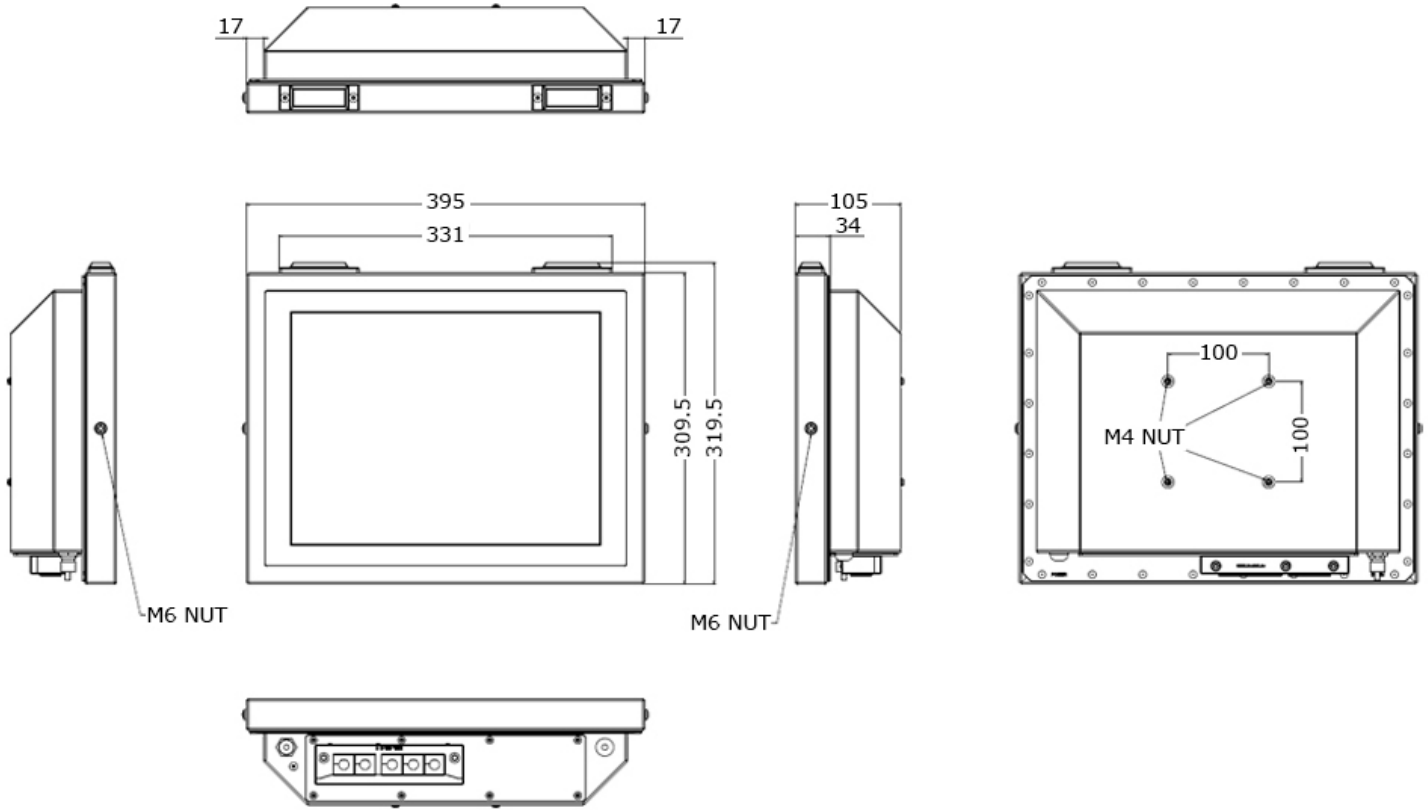

**USA**

Teguar  
2920 Whitehall Park Drive  
Charlotte, NC 28273  
+1 866-693-3105  
sales@teguar.com

**EUROPE**

Teguar Europe AG  
Churerstrasse 54, CH-8808  
Pfäffikon, Switzerland  
+41 41 561 53 11  
sales.EU@teguar.com

**ASIA**

Teguar Taiwan Ltd.  
Rm. A, 28F-12., No.99, Sec. 1, Xintai 5th Rd.,  
Xizhi Dist., New Taipei City 221, Taiwan (R.O.C.)  
+886 2 7751 5319  
sales@teguar.com.tw