

# TWB-2945

Waterproof PC



## Key Highlights

- Intel Bay Trail N2930 1.83GHz SoC CPU
- IP67 Waterproof Rated & IP69K Compliant
- Sleek Fanless Stainless Steel Design
- M12 Input/Output Connectors
- Incredibly Low 6.3W Consumption

[VIEW ONLINE](#)

This industrial stainless steel box PC can be used in a wide variety of applications that require rugged and compact computer design. The TWB-2945 is a sleek IP67 and IP69K rated waterproof box PC with a fully sealed, fanless design. Powered by an Intel Bay Trail N2930 1.83GHz SoC processor, the TWB-2945 has an ultra-low power consumption of 6.3W. For added configurability, this computer comes with an internal mini-PCIe slot and internal SD slot (up to 32GB).

### USA

Teguar  
2920 Whitehall Park Drive  
Charlotte, NC 28273  
+1 866-693-3105  
sales@teguar.com

### EUROPE

Teguar Europe AG  
Churerstrasse 54, CH-8808  
Pfäffikon, Switzerland  
+41 41 561 53 11  
sales.EU@teguar.com

### ASIA

Teguar Taiwan Ltd.  
Rm. A, 28F-12., No.99, Sec. 1, Xintai 5th Rd.,  
Xizhi Dist., New Taipei City 221, Taiwan (R.O.C.)  
+886 2 7751 5319  
sales@teguar.com.tw

# Technical Specifications

## Primary Components

|                  |                                    |
|------------------|------------------------------------|
| Processor Family | Intel Celeron Bay Trail            |
| Processor Model  | N2930                              |
| Processor Speed  | 1.83 GHz                           |
| Memory Type      | Onboard DDR3                       |
| Memory Support   | 4GB, 8GB                           |
| Storage Type     | 1x 2.5" SATA Drive Bay for SSD/HDD |
| Storage Support  | 32GB-1TB                           |

## Operating Systems

|         |  |
|---------|--|
| Windows | Windows 10 IoT, Windows 10 Pro, Windows 7 Pro, Windows 8.1 Pro |
|---------|--|

## Enclosure

|                  |                 |
|------------------|-----------------|
| Material         | Stainless Steel |
| IP Rating        | IP67            |
| Color            | Silver          |
| Control Buttons  | Power Button    |
| Mounting Options | Wall Mount      |

## Certification

|                |                 |
|----------------|-----------------|
| Certifications | CE, FCC Class A |
|----------------|-----------------|

*Specifications subject to change.*

## External I/O Ports

|                        |                                    |
|------------------------|------------------------------------|
| USB                    | 1x M12 8Pin for USB 1/2            |
| Serial / Com           | 2x COM                             |
| Serial Protocol Detail | 1x RS-232, 1x RS-232/422/485 (M12) |
| Ethernet / LAN         | 1x RJ45 GbE LAN                    |
| Video Outputs          | 1x VGA                             |
| Power Input Port       | M12 type 3-PIN DC-in               |

## Power

|                     |          |
|---------------------|----------|
| Input Voltage Range | 9-36V DC |
|---------------------|----------|

## Thermal & Environmental

|                       |                              |
|-----------------------|------------------------------|
| Operating Temperature | -20°C - 60°C (-4°F - 140°F)  |
| Storage Temperature   | -40°C - 85°C (-40°F - 185°F) |
| Cooling Solution      | Passive - Fanless            |
| Humidity Range        | 10% - 90% Non-condensing     |

## Weight / Dimensions

|            |  |
|------------|--|
| Weight     | 3.1 kg (6.8 lbs)                         |
| Dimensions | 250 x 200 x 58.6 mm (9.8 x 7.9 x 2.3 in) |

## Warranty

|          |               |
|----------|---------------|
| Warranty | Up to 5 Years |
|----------|---------------|

### USA

Teguar  
2920 Whitehall Park Drive  
Charlotte, NC 28273  
+1 866-693-3105  
sales@teguar.com

### EUROPE

Teguar Europe AG  
Churerstrasse 54, CH-8808  
Pfäffikon, Switzerland  
+41 41 561 53 11  
sales.EU@teguar.com

### ASIA

Teguar Taiwan Ltd.  
Rm. A, 28F-12., No.99, Sec. 1, Xintai 5th Rd.,  
Xizhi Dist., New Taipei City 221, Taiwan (R.O.C.)  
+886 2 7751 5319  
sales@teguar.com.tw

## I/O Diagram Images



### USA

Teguar  
2920 Whitehall Park Drive  
Charlotte, NC 28273  
+1 866-693-3105  
sales@teguar.com

### EUROPE

Teguar Europe AG  
Churerstrasse 54, CH-8808  
Pfäffikon, Switzerland  
+41 41 561 53 11  
sales.EU@teguar.com

### ASIA

Teguar Taiwan Ltd.  
Rm. A, 28F-12., No.99, Sec. 1, Xintai 5th Rd.,  
Xizhi Dist., New Taipei City 221, Taiwan (R.O.C.)  
+886 2 7751 5319  
sales@teguar.com.tw

# Tech Diagram Images

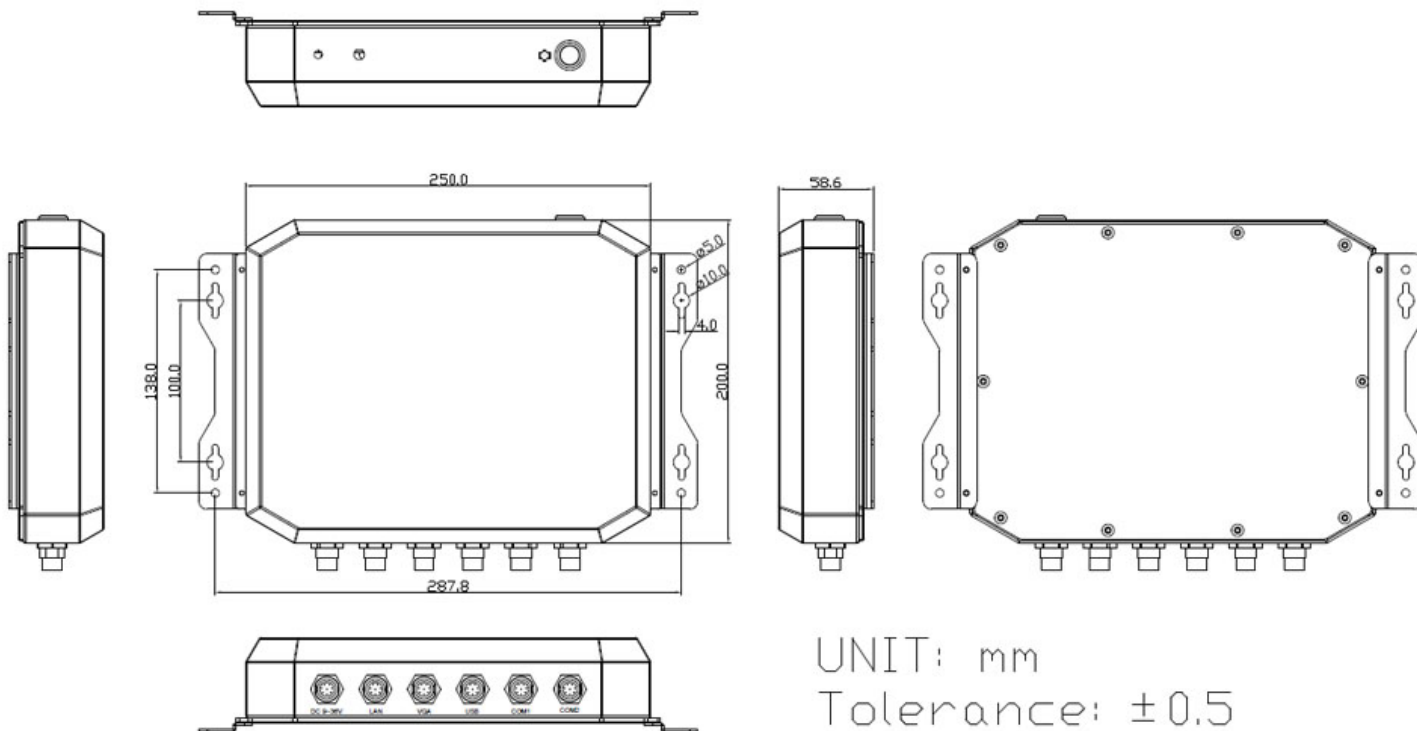

UNIT: mm  
Tolerance:  $\pm 0.5$

## USA

Teguar  
2920 Whitehall Park Drive  
Charlotte, NC 28273  
+1 866-693-3105  
sales@teguar.com

## EUROPE

Teguar Europe AG  
Churerstrasse 54, CH-8808  
Pfäffikon, Switzerland  
+41 41 561 53 11  
sales.EU@teguar.com

## ASIA

Teguar Taiwan Ltd.  
Rm. A, 28F-12., No.99, Sec. 1, Xintai 5th Rd.,  
Xizhi Dist., New Taipei City 221, Taiwan (R.O.C.)  
+886 2 7751 5319  
sales@teguar.com.tw