

TP-3445-08

8" Panel Mount Computer



Key Highlights

- 8" Pcap or Resistive Touchscreen
- Intel Apollo Lake N4200 Quad Core CPU
- Fanless Design and Aluminum Housing
- IP66 Rated Full-Flat Front Bezel
- Wide Range DC 9~36V Power Input

[VIEW ONLINE](#)

The TP-3445-08 Industrial [Panel PC](#) is slim and compact. Fit this computer into a cut out on your machine, on your production line, or into a control cabinet. This PC is built with die-cast aluminum housing and has fanless heatsink cooling. It also has an IP66 rated front bezel and accessible storage via 3 screws on the back of the unit. The TP-3445-08 runs on an Intel Apollo Lake CPU and has DC 9~36V wide range power input. This industrial grade computer is built to last, even in tough manufacturing environments.

USA

Teguar
2920 Whitehall Park Drive
Charlotte, NC 28273
+1 866-693-3105
sales@teguar.com

EUROPE

Teguar Europe AG
Churerstrasse 54, CH-8808
Pfäffikon, Switzerland
+41 41 561 53 11
sales.EU@teguar.com

ASIA

Teguar Taiwan Ltd.
Rm. A, 28F-12., No.99, Sec. 1, Xintai 5th Rd.,
Xizhi Dist., New Taipei City 221, Taiwan (R.O.C.)
+886 2 7751 5319
sales@teguar.com.tw

Technical Specifications

Primary Components

Processor Family	Intel Pentium Apollo Lake
Processor Model	N4200
Processor Speed	1.10 GHz
Memory Type	Onboard DDR3
Memory Support	4GB, 8GB
Storage Type	1.8" Half Size MO297 SATA Drive Bay
Storage Support	32GB-256GB

Power

Input Voltage Range	9-36V DC
Standard Power Adapter	Optional 12V AC/DC Adapter

Operating Systems

Windows	Windows 10 IoT, Windows 10 Pro
Linux	Linux (Contact your sales rep for more information)

Expansion Slots

SD card	1x Micro SD Slot
---------	------------------

Thermal & Environmental

Operating Temperature	0°C - 50°C (32°F - 122°F)
Storage Temperature	-30°C - 70°C (-22°F - 158°F)
Cooling Solution	Passive - Fanless with Heatsink
Humidity Range	10% - 90% Non-condensing

Weight / Dimensions

Weight	1.9 kg (4.2 lbs)
Dimensions	231 x 176 x 50 mm (9.1 x 6.9 x 2.0 in)

Certification

Certifications	CE, FCC Class A, UL 60950, UL 62368
----------------	-------------------------------------

Specifications subject to change.

Display

Screen Size	8"
Screen Resolution	800 x 600 (SVGA)
Screen Ratio	4:3
Brightness	350 nits, Optional 1000 nit High Brightness

Touch Screen

Touch Screen	Projected Capacitive, Resistive
--------------	---------------------------------

External I/O Ports

USB	2x USB 3.0
Serial / Com	2x COM
Serial Protocol Detail	1x RS-232/422/485 DB-9, default RS-232(COM1), 1x RS-232 DB-9(COM2)
Ethernet / LAN	2x RJ45 GbE LAN
Video Outputs	1x HDMI
Other Ports	1x 2-Pin DC Power Switch Connector
Audio Ports	1x Audio Line-Out
Power Input Port	3-Pin DC-In (Phoenix Type)

Enclosure

Material	Aluminum
IP Rating	IP66 Front Bezel
Mounting Options	Panel Mount, VESA 75 Mount

Peripherals & Wireless Connectivity

WiFi	Optional WiFi
Bluetooth	Optional Bluetooth 4.0
Mobile Network 4G LTE	Optional 4G

Warranty

Warranty	Up to 5 Years
----------	---------------

USA

Teguar
2920 Whitehall Park Drive
Charlotte, NC 28273
+1 866-693-3105
sales@teguar.com

EUROPE

Teguar Europe AG
Churerstrasse 54, CH-8808
Pfäffikon, Switzerland
+41 41 561 53 11
sales.EU@teguar.com

ASIA

Teguar Taiwan Ltd.
Rm. A, 28F-12., No.99, Sec. 1, Xintai 5th Rd.,
Xizhi Dist., New Taipei City 221, Taiwan (R.O.C.)
+886 2 7751 5319
sales@teguar.com.tw

I/O Diagram Images

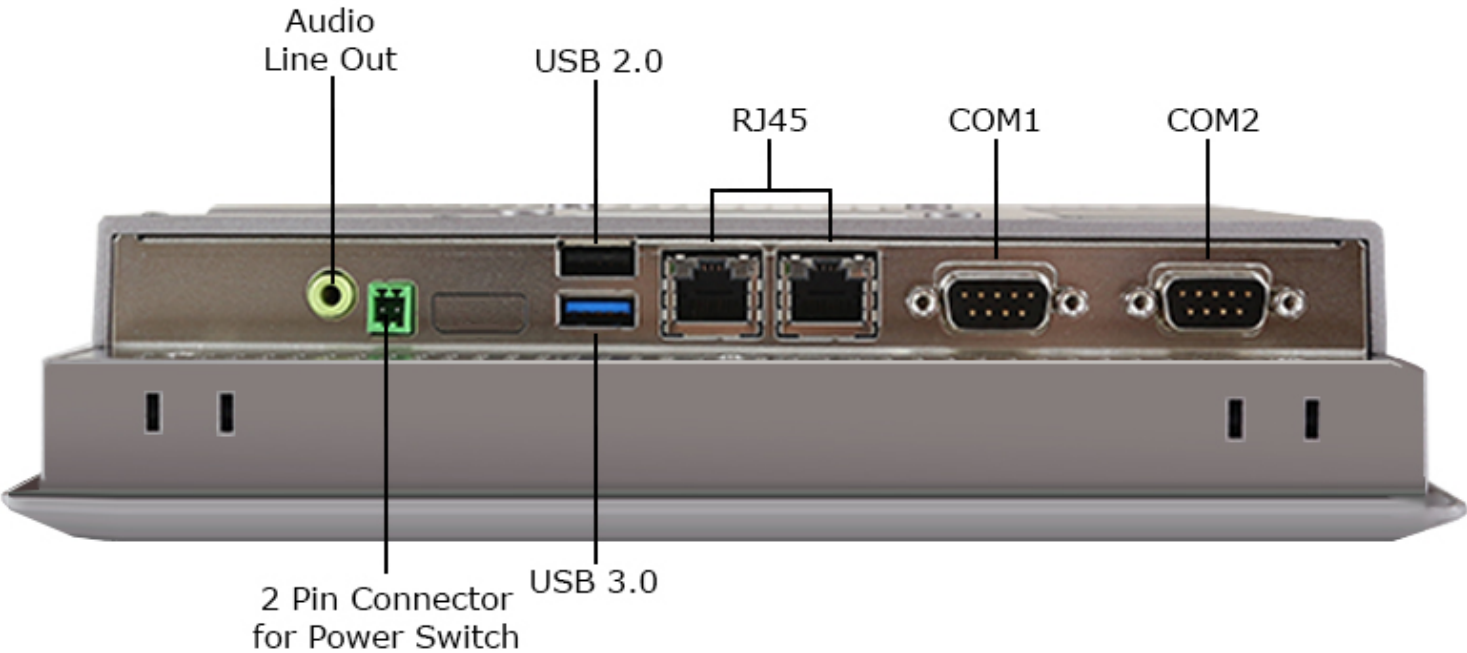

USA

Teguar
2920 Whitehall Park Drive
Charlotte, NC 28273
+1 866-693-3105
sales@teguar.com

EUROPE

Teguar Europe AG
Churerstrasse 54, CH-8808
Pfäffikon, Switzerland
+41 41 561 53 11
sales.EU@teguar.com

ASIA

Teguar Taiwan Ltd.
Rm. A, 28F-12., No.99, Sec. 1, Xintai 5th Rd.,
Xizhi Dist., New Taipei City 221, Taiwan (R.O.C.)
+886 2 7751 5319
sales@teguar.com.tw

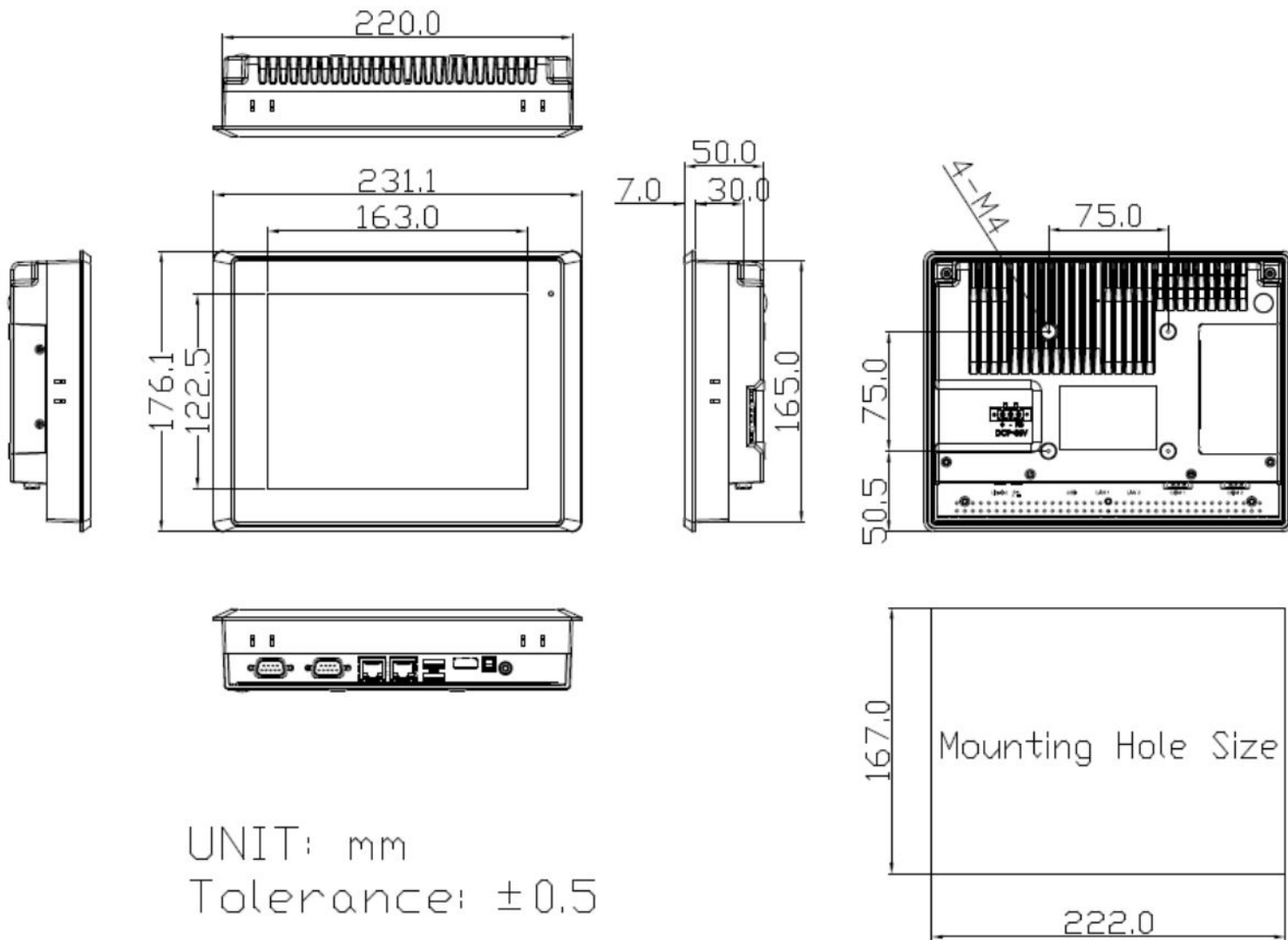

USA

Teguar
2920 Whitehall Park Drive
Charlotte, NC 28273
+1 866-693-3105
sales@teguar.com

EUROPE

Teguar Europe AG
Churerstrasse 54, CH-8808
Pfäffikon, Switzerland
+41 41 561 53 11
sales.EU@teguar.com

ASIA

Teguar Taiwan Ltd.
Rm. A, 28F-12., No.99, Sec. 1, Xintai 5th Rd.,
Xizhi Dist., New Taipei City 221, Taiwan (R.O.C.)
+886 2 7751 5319
sales@teguar.com.tw