



## Features

- 17" LED Backlit Full Flat Resistive/P-cap Touch Panel
- Intel 6th Generation Skylake Core i3/i5/i7 CPU
- HDD Anti-vibration Mechanism
- IP66 Rated Front Side
- Optional Wireless Connectivity

## Technical Specifications

### Primary Components

Processor Family	Intel Core I series 6th Generation Skylake
Processor Model	Core i5-6200U
Processor Speed	2.3 GHz
Memory Type	2x DDR4 SO-DIMM
Memory Support	4GB, 8GB, 16GB, 32GB
Storage type	1x 2.5" SATA Drive Bay for SSD/HDD, M.2, mSATA
Storage support	32GB-1TB

### Display

Screen Size	17"
Resolution	1280 x 1024 (SXGA)
Screen Ratio	5:4
Brightness	350 nits
Contrast Ratio	1000:1
Viewing Angle	170° (H), 160° (V)
Number of Colors Supported	16.2M

### Touch Screen

Touch Screen	Projected Capacitive, Resistive
Light Transmission	Over 80% (Resistive), Over 90% (P-Cap)
Hardness	Resistive: 4H, P-cap: 7H

### Expansion Slots

Internal Mini PCIe	1x Mini-PCIe
Internal M.2	1x M.2 Type E
video card support	Intel Integrated HD Graphics 520

### Thermal and Environmental

Operating Temperature	Array (32°F – 122°F)
Storage Temperature	Array (-4°F – 140°F)
Humidity Range	10% – 90% Non-condensing
Storage Humidity	10% – 90% Non-condensing
Cooling Solution	Passive – Fanless

### Enclosure

Material	Aluminum, Optional Stainless Steel Bezel, Steel
Ip Rating	IP66 Front Bezel
Color	Black
Control Buttons	Power Button, Power Reset
Mounting Options	Panel Mount, VESA Mount

**External I/O ports**

USB	4x USB 3.0
Serial / Com	2x COM
Serial Protocol Detail	1x RS-232, 1x RS-232/422/485 (RS485 supports auto flow control)
Ethernet / LAN	2x RJ45 GbE LAN
Video Outputs	2x DisplayPort
Audio	1x Audio Line-Out, 1x 3.5mm Microphone Jack
Power Input Port	4-Pole DIN (latching)

**Power**

Input Voltage Range	7-32V DC
Max Power consumption	61.4W
Standard Power Adapter	Optional, 100 watts, universal 100 ~240V AC in, 12V DC out, 8.33A

**Operating Systems**

Windows	Windows 10 IoT, Windows 10 Pro, Windows 7 Pro
---------	---

**Compatibility**

Security Hardware	Optional TPM 2.0
-------------------	------------------

**Peripherals & Wireless Connectivity**

WiFi	Optional 802.11 ac + Bluetooth 4.0 with External Antennas
------	---

**Dimensions / Weight**

Weight	8.5 KG (18.7 lbs)
Dimensions	426.2 x 358.6 x 90 mm (16.8 x 14.1 x 3.5 in)

**Certification**

Certifications	CE, FCC Class B, VCCI
----------------	-----------------------

**Warranty**

Warranty	Up to 5 Years
----------	---------------

**Inputs / Outputs**



Technical Drawings

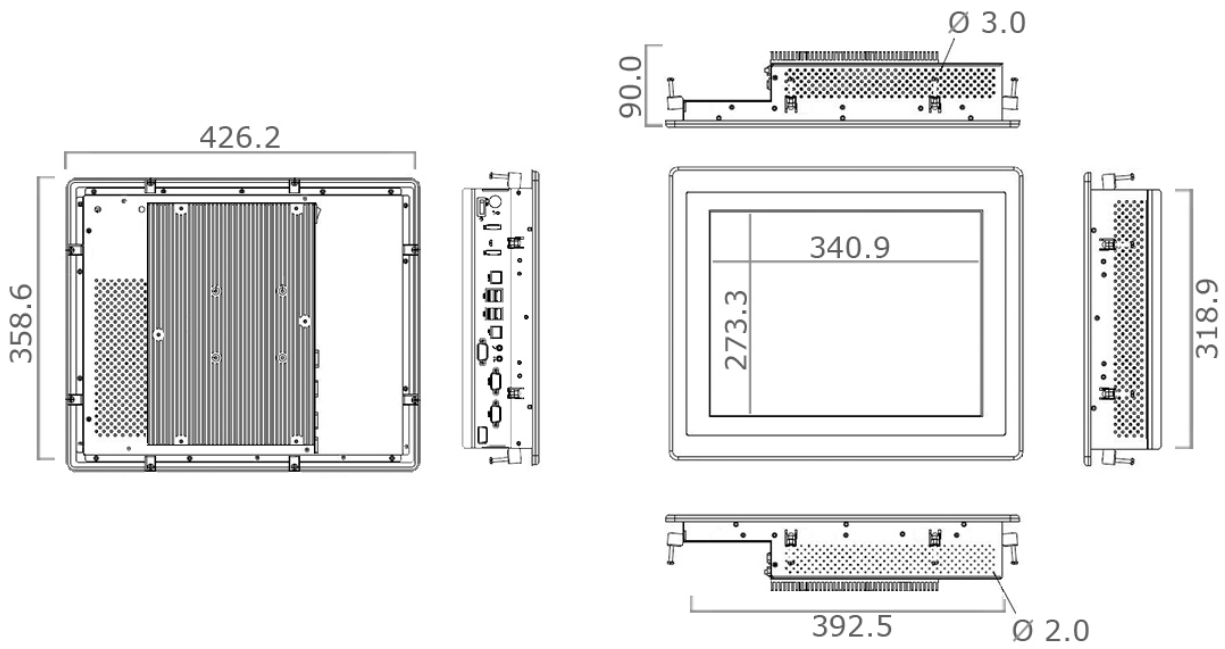

*All specifications are subject to change without notice.*