



Features

- 15" LCD Touchscreen
- Intel 6th Gen. Core i3/i5 CPU
- Grade 304 Stainless Steel Bezel
- IP66/IP69K Compliant Front
- Wide Range DC 9~36V Power Input

Technical Specifications

Primary Components

Processor Family	Intel Core I series 6th Generation Skylake
Processor Model	Core i3-6100U
Processor Speed	2.3 GHz
Memory Type	1x DDR4 SO-DIMM
Memory Support	4GB, 8GB, 16GB
Storage type	1x 2.5" SATA Drive Bay for SSD/HDD (easily accessible)
Storage support	32GB-1TB

Display

Screen Size	15"
Resolution	1024 x 768 (XGA)
Screen Ratio	4:3
Brightness	420 nits, Optional 1000 nit High Brightness
Contrast Ratio	800:1
Viewing Angle	160° (H), 140° (V), 145° (H), 160° (V) High Brightness
Number of Colors Supported	16.7M

Touch Screen

Touch Screen	Projected Capacitive, Resistive
Light Transmission	Over 80% (Resistive), Over 90% (P-Cap)
Lifetime Usage	30,000 hrs, 50,000 hrs (High Brightness)

Expansion Slots

Internal Mini PCIe	1x Mini-PCIe
SD card	1x Full Size SD Slot

Multimedia

Thermal and Environmental

Operating Temperature	Array (32°F – 122°F)
Storage Temperature	Array (-4°F – 140°F)
Storage Humidity	10% – 90% Non-condensing
Cooling Solution	Passive – Fanless

External I/O ports

USB	2x USB 3.0
Serial / Com	2x COM
Serial Protocol Detail	1x RS-232/422/485 DB-9, default RS-232(COM1), 1x RS-232 DB-9(COM2)
Ethernet / LAN	2x RJ45 GbE LAN
Video Outputs	1x Optional HDMI
Audio	1x Audio Line-Out
Power Input Port	3-Pin DC-In (Phoenix Type)

Power

Input Voltage Range	9-36V DC
Max Power consumption	42W
Standard Power Adapter	Optional 12V AC/DC Adapter

Battery

Operating Systems

Windows	Windows 10 IoT, Windows 10 Pro, Windows 7 Pro
---------	---

Compatibility

Security Hardware	TPM 2.0
-------------------	---------

Enclosure

Material	Aluminum, SUS304 Stainless Steel, Optional SUS316 Stainless Steel
Ip Rating	IP66 Front Bezel, IP69K Front Bezel
Mounting Options	Panel Mount, VESA 100 Mount

Peripherals & Wireless Connectivity

WiFi	WiFi
------	------

Dimensions / Weight

Weight	4.4 KG (9.7 lbs)
Dimensions	422 x 322 x 54 mm (16.6 x 12.7 x 2.1 in)

Certification

Certifications	CE, EN 1672-2 Complaint (PCAP Touchscreen Only), FCC Class A
----------------	--

Warranty

Warranty	Up to 5 Years
----------	---------------

Inputs / Outputs



Technical Drawings

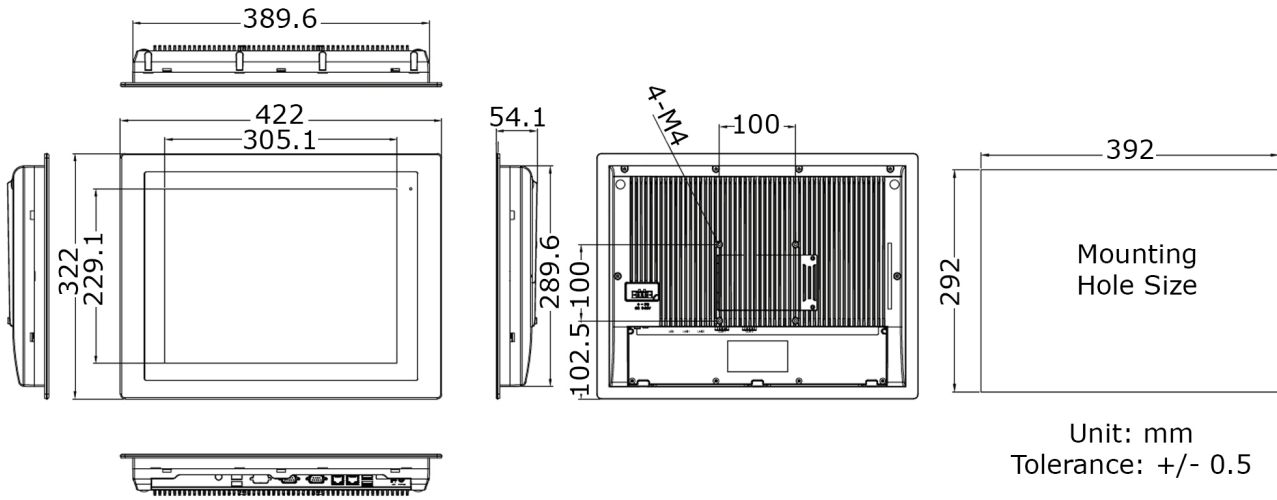

All specifications are subject to change without notice.