



Features

- 15" P-Cap Touchscreen
- Intel Bay Trail Atom Quad Core CPU
- IP66 Rated Enclosure w/ IP67 Connectors
- Onboard DDR3 with up to 8GB RAM
- High-brightness Screen w/ AR Coating
- Wide Temperature Range Tolerance

Technical Specifications

Primary Components

| | |
|------------------|------------------------------------|
| Processor Family | Intel Atom Bay Trail |
| Processor Model | E3845 |
| Processor Speed | 1.91 GHz |
| Memory Type | 2x DDR3 SO-DIMM |
| Memory Support | 4GB |
| Storage type | 1x 2.5" SATA Drive Bay for SSD/HDD |
| Storage support | 128GB - 512GB |

Display

| | |
|----------------|--------------------|
| Screen Size | 15" |
| Resolution | 1024 x 768 (XGA) |
| Screen Ratio | 4:3 |
| Brightness | 1000 nits |
| Contrast Ratio | 700:1 |
| Viewing Angle | 160° (H), 140° (V) |

Touch Screen

| | |
|--------------------|----------------------|
| Touch Screen | Projected Capacitive |
| Light Transmission | Over 90% |
| Hardness | 7H |

Expansion Slots

| | |
|--------------------|-------------------|
| Internal Mini PCIe | 2x Mini-PCIe |
| video card support | Intel HD Graphics |

Thermal and Environmental

| | |
|-----------------------|---|
| Operating Temperature | Array (-4°F – 140°F) |
| Storage Temperature | Array (-4°F – 149°F) |
| Humidity Range | 10% – 90% Non-condensing |
| Cooling Solution | Passive– Heatsink with Backup Smart Fan |

Enclosure

| | |
|------------------|-------------------------|
| Material | SUS304 Stainless Steel |
| Ip Rating | IP66 |
| Color | White |
| Mounting Options | Panel Mount, VESA Mount |

External I/O ports

| | |
|------------------------|-------------------------|
| USB | 1x M12 8Pin for USB 1/2 |
| Serial / Com | 2x COM |
| Serial Protocol Detail | 2x RS-232 |
| Ethernet / LAN | 1x RJ45 GbE LAN |
| Power Input Port | M12 type 5-PIN DC-in |

Power

| | |
|------------------------|------------------------|
| Input Voltage Range | 7-32V DC |
| Max Power consumption | 42W |
| Standard Power Adapter | IP67 24V AC/DC Adapter |

Operating Systems

| | |
|---------|-------------------------------|
| Windows | Windows 10 Pro, Windows 7 Pro |
|---------|-------------------------------|

Compatibility

| | |
|-------------------|------------------|
| Security Hardware | Optional TPM 2.0 |
|-------------------|------------------|

Peripherals & Wireless Connectivity

| | |
|------|---------------|
| WiFi | Optional WLAN |
|------|---------------|

Dimensions / Weight

| | |
|------------|--|
| Weight | 12 KG (26.5 lbs) |
| Dimensions | 415 x 329.5 x 85 mm (16.3 x 13.0 x 3.3 in) |

Certification

| | |
|----------------|---------------|
| Certifications | CE, FCC, VCCI |
|----------------|---------------|

Warranty

| | |
|----------|---------------|
| Warranty | Up to 5 Years |
|----------|---------------|

Inputs / Outputs



Technical Drawings

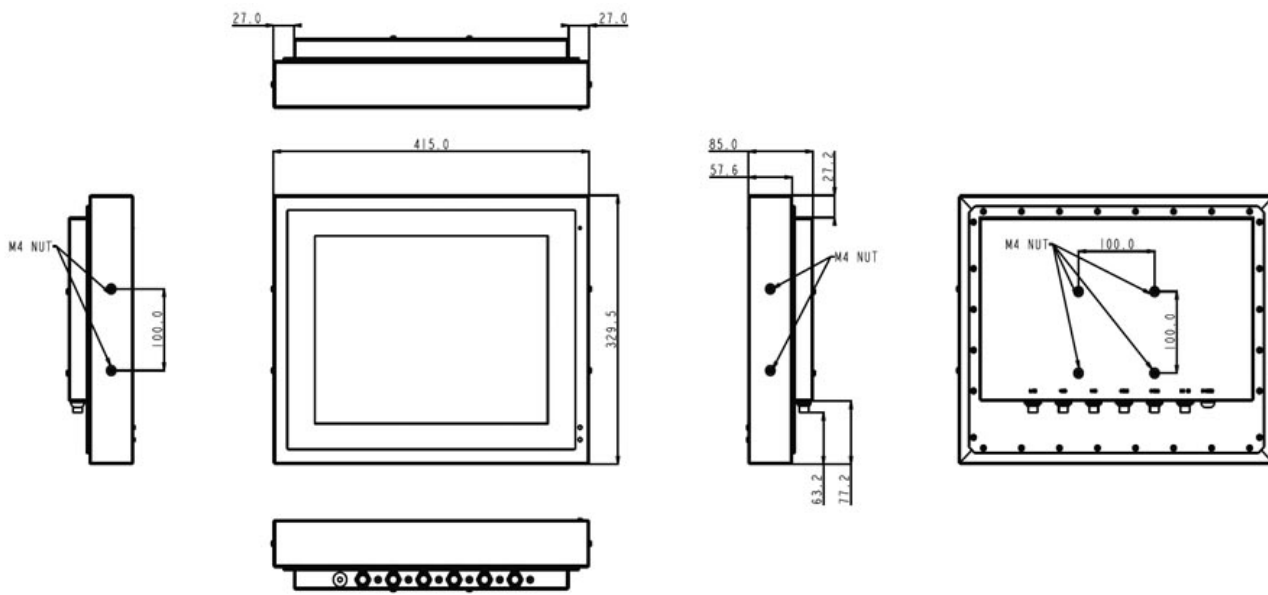

All specifications are subject to change without notice.