



Features

- 15.1" PCap Touchscreen
- ARM Cortex A9 Dual Core CPU
- Fanless and Ultra-Low Power Consumption
- Full IP65 Waterproof Rated
- Optional Power over Ethernet

Technical Specifications

Primary Components

Processor Speed	1.0 GHz
Memory Support	1GB, 2GB, 4GB

Display

Screen Size	15"
Resolution	1024 x 768 (XGA)
Brightness	250 nits, Optional 1000 nit High Brightness
Contrast Ratio	700:1

Touch Screen

Touch Screen	Projected Capacitive
--------------	----------------------

External I/O ports

USB	1x Micro USB 2.0 OTG, 1x M12 USB
Serial Protocol Detail	1x M12 RS-232

Operating Systems

Android	Android 6.0.1
---------	---------------

Enclosure

Ip Rating	IP65
Color	Black
Mounting Options	Panel Mount, VESA 100 Mount

Dimensions / Weight

Weight	5 KG (11.0 lbs)
Dimensions	353.4 x 255.86 x 45.2 mm (13.9 x 10.1 x 1.8 in)

Warranty

Warranty	Up to 5 Years
----------	---------------

Inputs / Outputs

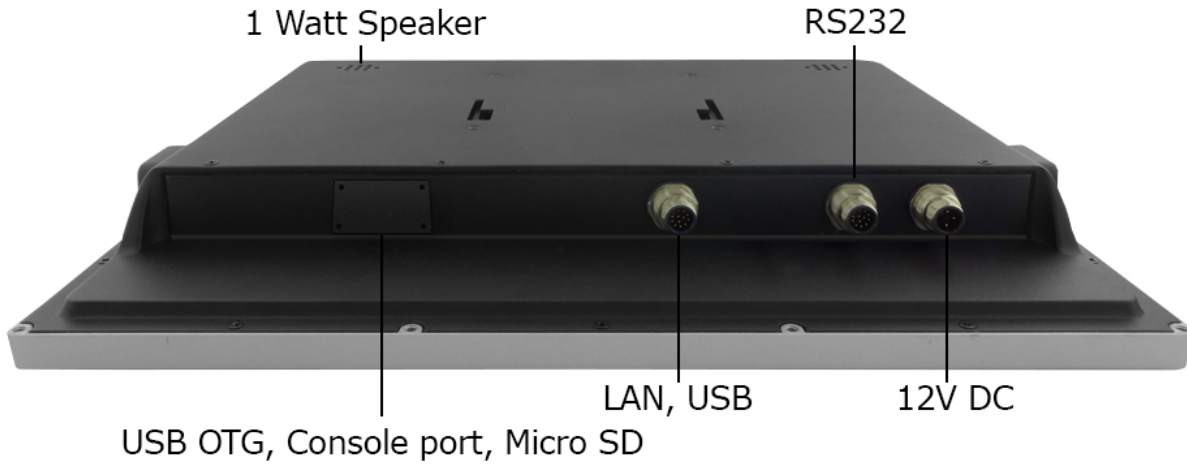

Technical Drawings

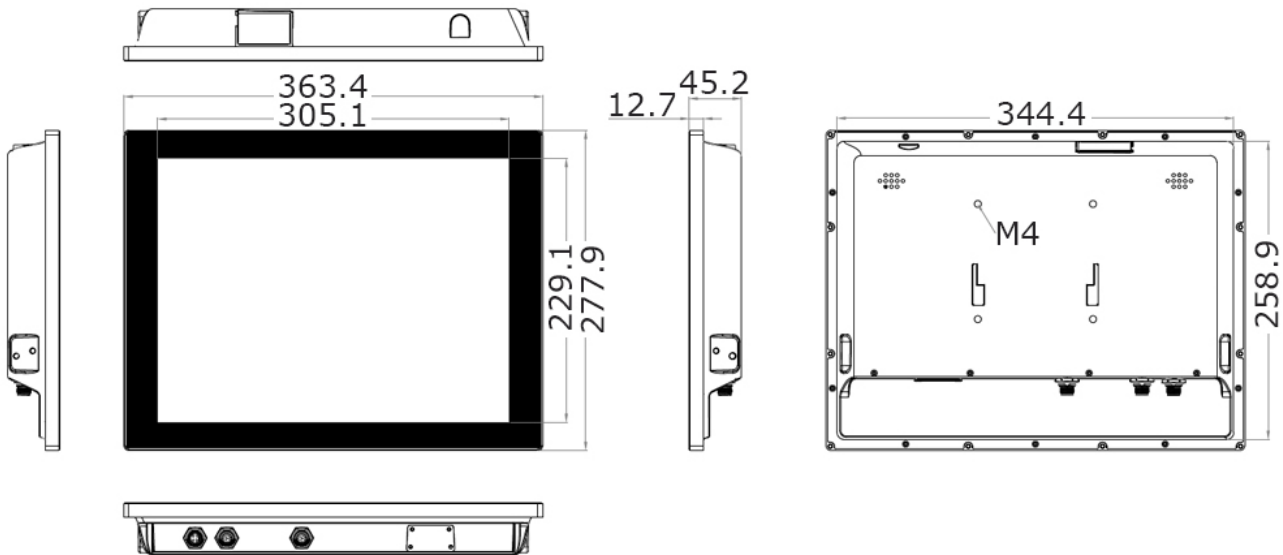

All specifications are subject to change without notice.